

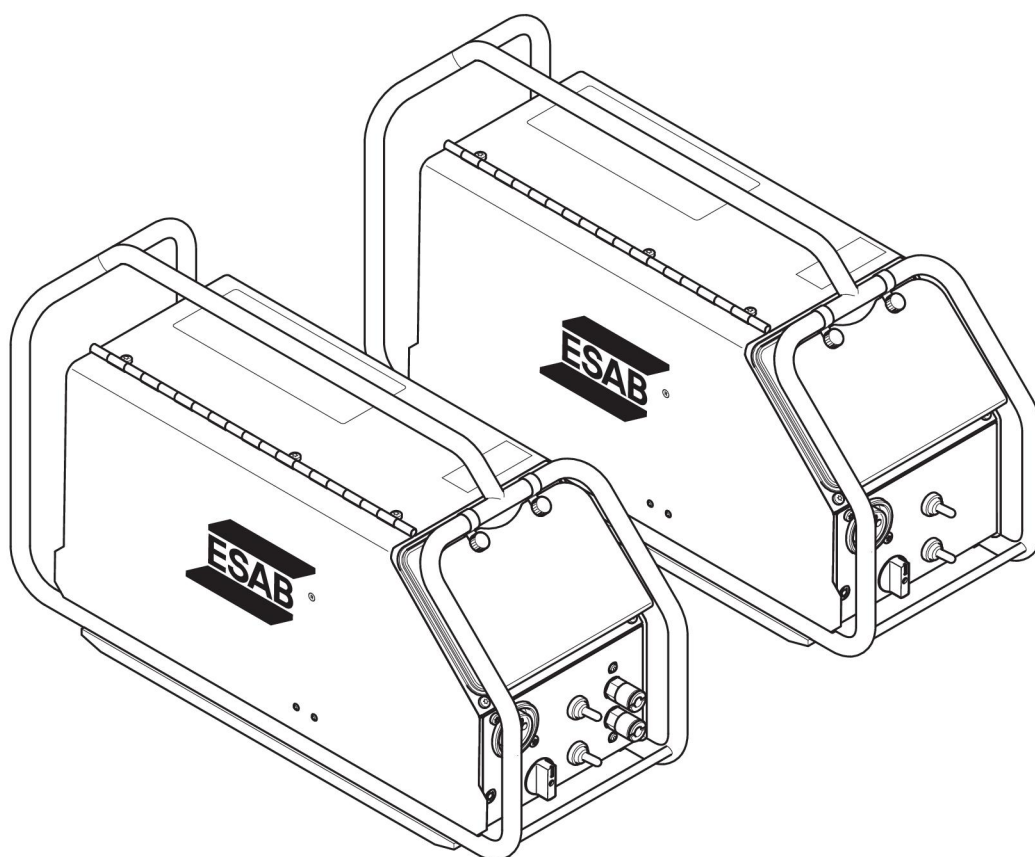

Warrior™ YardFeed 200, Warrior™ YardFeed 200w



Instruction manual

TABLE OF CONTENTS

1	SAFETY	3
1.1	Meaning of symbols	3
1.2	Safety precautions	3
1.3	User responsibility	7
2	INTRODUCTION	11
3	TECHNICAL DATA	12
4	INSTALLATION	13
4.1	Lifting instructions	13
5	OPERATION	14
5.1	Connections and control devices	15
5.2	Function	16
5.3	Wire feed pressure	17
5.4	Replacing and inserting wire	18
5.5	Changing feed rollers	18
6	MAINTENANCE	19
6.1	Inspection and cleaning	19
7	ORDERING SPARE PARTS	20
	DIAGRAM	21
	ORDERING NUMBERS	23
	WEAR PARTS	24
	ACCESSORIES	29

1 SAFETY

1.1 Meaning of symbols

As used throughout this manual: Means Attention! Be Alert!



DANGER!

Means immediate hazards which, if not avoided, will result in immediate, serious personal injury or loss of life.



WARNING!

Means potential hazards which could result in personal injury or loss of life.



CAUTION!

Means hazards which could result in minor personal injury.



WARNING!

Before use, read and understand the instruction manual and follow all labels, employer's safety practices and Safety Data Sheets (SDSs).



1.2 Safety precautions



WARNING!

These Safety Precautions are for your protection. They summarise precautionary information from the references listed in the Additional Safety Information section. Before performing any installation or operating procedures, be sure to read and follow the safety precautions listed below as well as all other manuals, material safety data sheets, labels, etc. Failure to observe the Safety Precautions could result in injury or death.



PROTECT YOURSELF AND OTHERS

Some welding, cutting and gouging processes are noisy and require hearing protection. The arc, like the sun, emits ultraviolet (UV) and other radiation and can injure the skin and eyes. Hot metal can cause burns. Training in the proper use of the processes and equipment is essential to prevent accidents. Therefore:

1. Wear a welding helmet fitted with a proper shade of filter to protect your face and eyes when welding or watching.
2. Always wear safety glasses with side shields in any work area, even if welding helmets, face shields and goggles are also required.
3. Use a face shield fitted with the correct filter and cover plates to protect your eyes, face, neck and ears from sparks and rays of the arc when operating or observing operations. Warn bystanders not to look at the arc and not to expose themselves to the rays of the electric-arc or hot metal.

4. Wear flameproof gauntlet-type gloves, heavy long-sleeve shirt, cuffless pants, high-topped shoes, and a welding helmet or cap for protection, to protect against arc rays and hot sparks or hot metal. A flameproof apron may also be desirable as protection against radiated heat and sparks.
5. Hot sparks or metal can lodge in rolled up sleeves, trouser cuffs, or pockets. Sleeves and collars should be kept buttoned and open pockets eliminated from the front of the clothing.
6. Protect other personnel from arc rays and hot sparks with a suitable non-flammable partition or curtains.
7. Use goggles over safety glasses when chipping slag or grinding. Chipped slag may be hot and can fly for long distances. Bystanders should also wear goggles over safety glasses.



FIRES AND EXPLOSIONS

The heat from flames and arcs can start fires. Hot slag or sparks can also cause fires and explosions. Therefore:

1. Protect yourself and others from flying sparks and hot metal.
2. Move all combustible materials well away from the work area or cover the materials with a protective non-flammable covering. Combustible materials include wood, cloth, sawdust, liquid and gas fuels, solvents, paints, and coating paper, etc.
3. Hot sparks or hot metal can fall through cracks or crevices in floors or wall openings and cause a hidden smoldering fire or fires on the floor below. Make certain that such openings are protected from hot sparks and metal.
4. Do not weld, cut, or perform other hot work until the work piece has been completely cleaned so that there are no substances on the work piece which might produce flammable or toxic vapors. Do not perform hot work on closed containers, they may explode.
5. Have fire extinguishing equipment handy for instant use, such as a garden hose, water pail, sand bucket, or portable fire extinguisher. Be sure you are trained in its use.
6. Do not use equipment beyond its ratings. For example, an overloaded welding cable can overheat and create a fire hazard.
7. After completing work, inspect the work area to make sure there are no hot sparks or hot metal that could cause a fire later. Use fire watchers when necessary.



ELECTRICAL SHOCK

Contact between live electrical parts and earth can cause severe injury or death. DO NOT use AC welding current in damp areas, if movement is confined, or if there is danger of falling. Therefore:

1. Be sure the power source frame (chassis) is connected to the earth system of the input power.
2. Connect the workpiece to a good electrical earth.
3. Connect the work cable to the workpiece. A poor or missing connection can expose you or others to a fatal shock.
4. Use well-maintained equipment. Replace worn or damaged cables.
5. Keep everything dry, including clothing, work area, cables, torch/electrode holder and power source.
6. Make sure that all parts of your body are insulated from both the work piece and from the ground.
7. Do not stand directly on metal or the ground while working in tight quarters or a damp area; stand on dry boards or an insulating platform and wear rubber-soled shoes.

8. Put on dry, hole-free gloves before turning on the power.
9. Turn off the power, before removing your gloves.
10. Refer to ANSI/ASC Standard Z49.1 for specific grounding recommendations. Do not mistake the work lead for a earth cable.



ELECTRIC AND MAGNETIC FIELDS

May be dangerous. Electric current flowing through any conductor causes localised Electric and Magnetic Fields (EMF). Welding and cutting current creates EMF around welding cables and welding machines. Therefore:

1. Welders with pacemakers fitted should consult their doctor before welding. EMF may interfere with some pacemakers.
2. Exposure to EMF may have other health effects which are unknown.
3. Welders should use the following procedures to minimise exposure to EMF:
 - a) Route the electrode and work cables together. Secure them with tape when possible.
 - b) Never coil the torch or work cable around your body.
 - c) Do not place your body between the torch and work cables. Route cables on the same side of your body.
 - d) Connect the work cable to the workpiece as close as possible to the area being welded.
 - e) Keep the welding power source and cables as far away from your body as possible.



FUMES AND GASES

Fumes and gases, can cause discomfort or harm, particularly in confined spaces. Shielding gases can cause asphyxiation. Therefore:

1. Keep your head out of the fumes. Do not breathe the fumes and gases.
2. Always provide adequate ventilation in the work area by natural or mechanical means. Do not weld, cut or gouge on materials such as galvanized steel, stainless steel, copper, zinc, lead beryllium or cadmium unless positive mechanical ventilation is provided. Do not breathe in the fumes from these materials.
3. Do not operate near degreasing and spraying operations. The heat or arc can react with chlorinated hydrocarbon vapors to form phosgene, a highly toxic gas, and other irritant gases.
4. If you develop momentary eye, nose or throat irritation while operating, this is an indication that the ventilation is not adequate. Stop work and take the necessary steps to improve ventilation in the work area. Do not continue to operate if physical discomfort persists.
5. Refer to ANSI/ASC Standard Z49.1 for specific ventilation recommendations.
6. **WARNING:** This product when used for welding or cutting, produces fumes or gases that contain chemicals known to the State of California to cause birth defects and in some cases cancer (California Health & Safety Code §25249.5 et seq.)



CYLINDER HANDLING

Cylinders, if mishandled, can rupture and violently release gas. A sudden rupture of cylinder valve or relief device can injure or kill. Therefore:

1. Locate cylinders away from heat, sparks and flames. Never strike an arc on a cylinder.
2. Use the proper gas for the process and use the proper pressure reducing regulator designed to operate from the compressed gas cylinder. Do not use adapters. Maintain hoses and fittings in good condition. Follow the manufacturer's operating instructions for mounting a regulator to a compressed gas cylinder.
3. Always secure cylinders in an upright position, by chain or strap, to suitable hand trucks, undercarriages, benches, wall, post or racks. Never secure cylinders to work tables or fixtures where they may become part of an electrical circuit.
4. When not in use, keep cylinder valves closed. Have valve protection cap in place if regulator is not connected. Secure and move cylinders by using suitable hand trucks.



MOVING PARTS

Moving parts, such as fans, rotors and belts can cause injury. Therefore:

1. Keep all doors, panels, guards, and covers closed and securely in place.
2. Stop the engine or drive systems before installing or connecting a unit.
3. Have only qualified people remove covers for maintenance and troubleshooting as necessary
4. To prevent accidental starting of equipment during service, disconnect negative (-) battery cable from battery.
5. Keep hands, hair, loose clothing and tools away from moving parts.
6. Reinstall panels or covers and close doors when service is finished and before starting engine.



WARNING!

FALLING EQUIPMENT CAN INJURE

- Only use lifting eye to lift unit. Do NOT use running gear, gas cylinders or any other accessories.
- Use equipment of adequate capacity to lift and support unit.
- If using lift forks to move unit, be sure forks are long enough to extend beyond opposite side of unit.
- Keep cables and cords away from moving vehicles when working from an aerial location.



WARNING!
EQUIPMENT MAINTENANCE

Faulty or improperly maintained equipment can cause injury or death. Therefore:

1. Always have qualified personnel perform the installation, troubleshooting and maintenance work. Do not perform any electrical work unless you are qualified to perform such work.
2. Before performing any maintenance work inside a power source, disconnect the power source from the incoming electrical power.
3. Maintain cables, earthing wire, connections, power cord and power supply in safe working order. Do not operate any equipment in faulty condition.
4. Do not abuse any equipment or accessories. Keep equipment away from heat sources such as furnaces, wet conditions such as water puddles, oil or grease, corrosive atmospheres and inclement weather.
5. Keep all safety devices and cabinet covers in position and in good repair.
6. Use equipment only for its intended purpose. Do not modify it in any manner.



CAUTION!
ADDITIONAL SAFETY INFORMATION

For more information on safe practices for electric arc welding and cutting equipment, ask your supplier for a copy of "Precautions and Safe Practices for Arc Welding, Cutting and Gouging." Form 52-529.

The following publications are recommended to you:

1. ANSI/ASC Z49.1 - "Safety in Welding and Cutting"
2. AWS C5.5 - "Recommended Practices for Gas Tungsten Arc Welding"
3. AWS C5.6 - "Recommended Practices for Gas Metal Arc Welding"
4. AWS SP - "Safe Practices" - Reprint, Welding Handbook
5. ANSI/AWS F4.1 - "Recommended Safe Practices for Welding and Cutting of Containers That Have Held Hazardous Substances"
6. OSHA 29 CFR 1910 - "Safety and Health Standards"
7. CSA W117.2 - "Code for Safety in Welding and Cutting"
8. NFPA Standard 51B, "Fire Prevention During Welding, Cutting, and Other Hot Work"
9. CGA Standard P-1, "Precautions for Safe Handling of Compressed Gases in Cylinders"
1. ANSI Z87.1, "Occupational and Educational Personal Eye and Face Protection Devices"
- 0.

1.3 User responsibility

Users of ESAB equipment have the ultimate responsibility for ensuring that anyone who works on or near the equipment observes all the relevant safety precautions. Safety precautions must meet the requirements that apply to this type of equipment. The following recommendations should be observed, in addition to the standard regulations that apply to the workplace.

All work must be carried out by trained personnel well-acquainted with the operation of the equipment. Incorrect operation of the equipment may lead to hazardous situations, which could result in injury to the operator and damage to the equipment.

1. Anyone who uses the equipment must be familiar with:
 - its operation
 - the location of emergency stops
 - its function
 - the relevant safety precautions
 - welding and cutting or other applicable operation of the equipment
2. The operator must ensure that:
 - no unauthorized person is within the working area of the equipment when it is started up
 - no-one is unprotected when the arc is struck or work is started with the equipment
3. The workplace must:
 - be suitable for the purpose
 - be free from drafts
4. Personal safety equipment:
 - Always wear recommended personal safety equipment, such as safety glasses, flame-proof clothing, safety gloves
 - Do not wear loose-fitting items, such as scarves, bracelets, rings, etc., which could become trapped or cause burns
5. General precautions:
 - Make sure the return cable is connected securely
 - Work on high voltage equipment **may only be carried out by a qualified electrician**
 - Appropriate fire extinguishing equipment must be clearly marked and close at hand
 - Lubrication and maintenance must **not** be carried out on the equipment during operation



WARNING!

Wire feeders are intended to be used in GMAW (MIG/MAG) mode only.

If used in any other welding mode, such as SMAW (MMA), the welding cable between wire feeder and power source must be disconnected, or else the wire feeder becomes live or energized.



WARNING!

Arc welding and cutting may cause injury to yourself and others. Take precautions when welding and cutting.



ELECTRIC SHOCK - Can kill

- Do not touch live electrical parts or electrodes with bare skin, wet gloves, or wet clothing
- Insulate yourself from work and ground.
- Ensure your working position is safe



ELECTRIC AND MAGNETIC FIELDS - Pose health risks

- Welders with pacemakers fitted should consult their doctor before welding. EMF may interfere with some pacemakers.
- Exposure to EMF may have other health effects which are unknown.
- Welders should use the following procedures to minimize exposure to EMF:
 - Route the electrode and work cables together on the same side of your body. Secure them with tape when possible. Do not place your body between the torch and work cables. Never coil the torch or work cable around your body. Keep the welding power source and cables as far away from your body as possible.
 - Connect the work cable to the workpiece as close as possible to the area being welded.



FUMES AND GASES - Can be dangerous to your health

- Keep your head out of the fumes
- Use ventilation, extraction at the arc, or both, to take fumes and gases away from your breathing zone and the general area



ARC RAYS - Can injure eyes and burn skin

- Protect your eyes and body. Use the correct welding screen and filter lens and wear protective clothing
- Protect bystanders with suitable screens or curtains



NOISE - Excessive noise can damage hearing

Protect your ears. Use ear defenders or other hearing protection.



MOVING PARTS - Can cause injuries

- Keep all doors, panels and covers closed and securely in place. Have only qualified people remove covers for maintenance and troubleshooting as necessary. Reinstall panels or covers and close doors when service is finished and before starting engine.
- Stop engine before installing or connecting unit.
- Keep hands, hair, loose clothing and tools away from moving parts.



FIRE HAZARD



- Sparks (spatter) can cause a fire. Therefore, make sure that there are no inflammable materials nearby
- Do not use on closed containers.

MALFUNCTION - Call for expert assistance in the event of malfunction.

PROTECT YOURSELF AND OTHERS!



CAUTION!

This product is solely intended for arc welding.

ESAB has an assortment of welding accessories and personal protection equipment for purchase. For ordering information, contact your local ESAB dealer or visit us on our website.

2 INTRODUCTION

The Warrior™ YardFeed 200 and Warrior™ YardFeed 200w wire feed units are intended for MIG/MAG (GMAW) welding together with welding power sources:

- Warrior 400i CC/CV
- Warrior 500i CC/CV

They are available in different versions, see chapter "ORDERING NUMBERS".

The wire feed units are sealed and contain a four-wheel drive wire feed mechanism as well as control electronics.

They can be used together with wire from ESAB, standard S200 Ø 8 in / Ø 200 mm.

ESAB accessories for the product can be found in the "ACCESSORIES" chapter of this manual.

3 TECHNICAL DATA

Warrior™ YardFeed 200	
Mains voltage	42 V, 50–60 Hz
Power requirement	252 VA
Rated supply current I₁	6 A
Settings data	
Wire feed speed	75 - 985 in/min (1.9 - 25.0 m/min)
2/4 stroke	2 stroke or 4 stroke
Wire selection / Burnback	Solid or Cored
Creep start	Always on
Gas purging	Yes
Wire inching	Yes
Torch connection	EURO
Wire bobbin: Type, Max. diameter	S200, 8 in (200 mm).
Wire dimension	
Fe	0.023 - 0.045 in (0.6 - 1.2 mm).
Ss	0.023 - 0.045 in (0.6 - 1.2 mm).
Al	0.040 - 0.045 in (1.0 - 1.2 mm).
Cored wire	0.030 - 1/16 in (0.8 - 1.6 mm)
Weight	
WYF 200	26.5 lb (12 kg)
WYF 200w	26.9 lb (12.2 kg)
Dimensions (l × w × h)	23.3 × 8.3 × 12.28 in (593 × 210 × 312 mm)
Operating temperature	-10 to +40 °C (+14 to +104 °F)
Transport and storage temperature	-20 to +55 °C (-4 to +131 °F)
Shielding gas	All types intended for MIG/MAG welding
max pressure	0.5 MPA (5 bar / 72.5 psi)
Maximum permissible load at	
60% duty cycle	365 A
100% duty cycle	280 A
Enclosure class	IP23

Standard factory settings

Standard factory settings for Warrior™ YardFeed 200 are in/min and fully open gas valve.

Duty cycle

The duty cycle refers to the time as a percentage of a ten-minute period that you can weld or cut at a certain load without overloading. The duty cycle is valid for 104 °F (40 °C).

Enclosure class

The **IP** code indicates the enclosure class, i.e. the degree of protection against penetration by solid objects or water.

Equipment marked **IP23** is intended for indoor and outdoor use.

4 INSTALLATION

The installation must be carried out by a professional.



WARNING!

When welding in an environment with increased electrical danger, only power sources intended for this environment may be used. These power sources are marked with the symbol **S**.

4.1 Lifting instructions

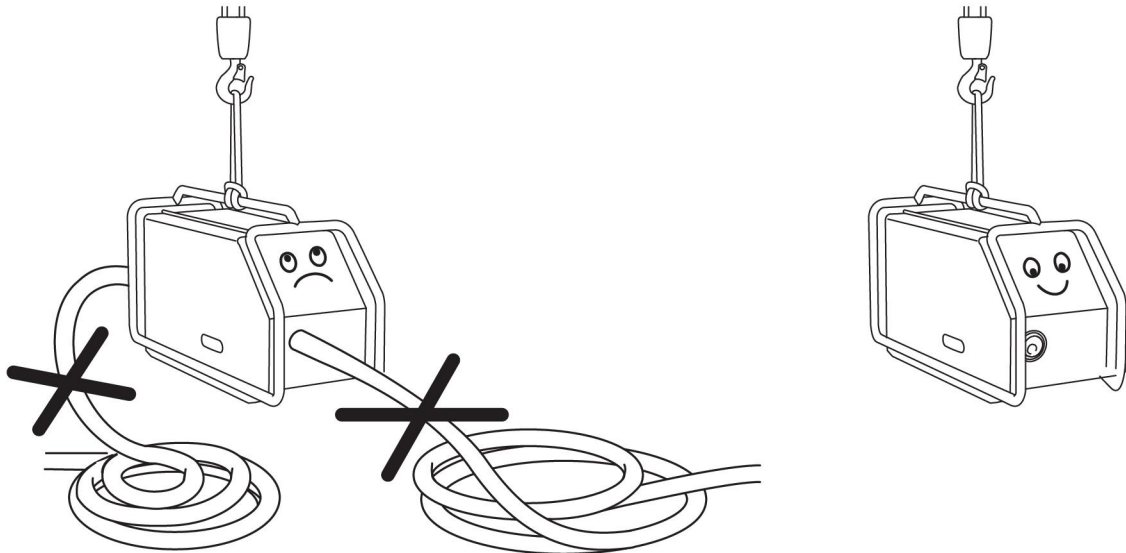

5 OPERATION

General safety regulations for handling the equipment can be found in the "SAFETY" chapter of this manual. Read it through before you start using the equipment!



WARNING!

To avoid shock, do not touch the electrode wire or parts in contact with it, or uninsulated cable or connections.



NOTE!

When moving the equipment, use the handle intended for transportation. Never pull the equipment by the welding torch.

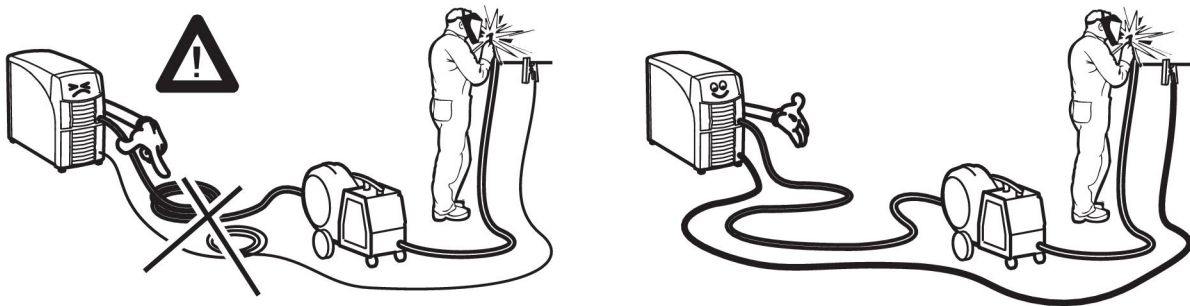

WARNING!

Make sure the side panels are closed during operation.



WARNING!

Rotating parts can cause injury, take great care.



WARNING!

Risk of crushing when replacing the wire bobbin!

Do **not** use safety gloves when inserting the welding wire between the feed rollers.

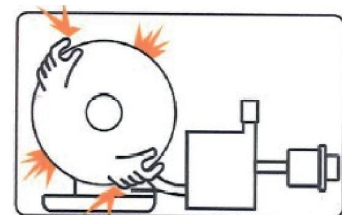

CAUTION!

Before threading welding wire, make sure the chisel point and burrs have been removed from the end of the wire to prevent the wire from jamming in the torch liner.

5.1 Connections and control devices

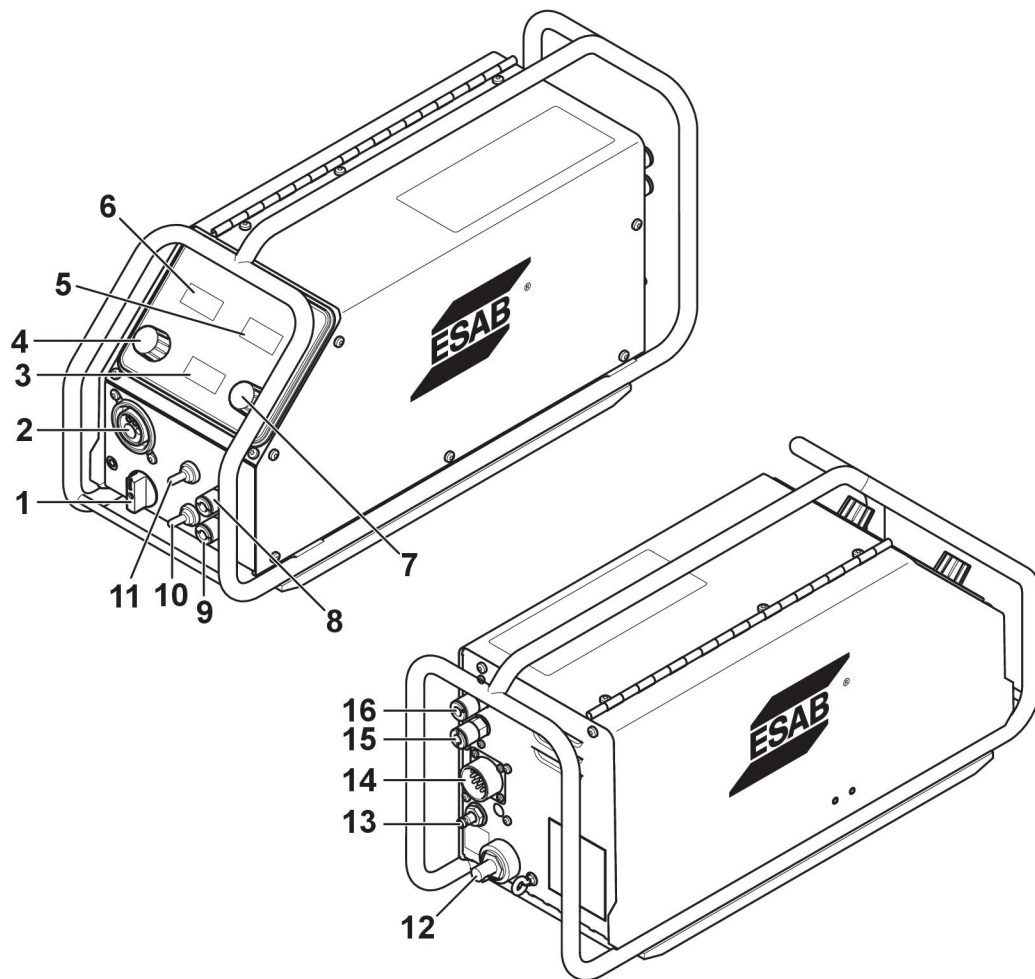

1	Safety contact switch	9	RED connection for cooling water to power source (cooling unit) **
2	Connection for welding torch (Euro connector)	10	Toggle switch for gas purging / wire inching
3	Display wire feed speed (in/min or m/min)*	11	Switch for 2 stroke / 4 stroke
4	Knob for setting the voltage	12	Connection for welding current from power source (OKC)
5	Display current (A)	13	Connection for shielding gas
6	Display voltage (V)	14	Connection for control cable from power source
7	Knob for setting the wire feed speed (m/min or in/min)	15	RED connection for coolant to power source (cooling unit)
8	BLUE connection for cooling water from power source (cooling unit) **	16	BLUE connection for coolant from power source (cooling unit)

*For setting of display wire feed speed unit, see the "Function" section.

** Cooling water connections are only available on certain models.

**NOTE!**

The display for wire feed speed is activated a few seconds after the safety contact switch is set to "Welding ON" mode (1).

**NOTE!**

Coolant connections are only available on certain models.

5.2 Function

Water connection

When connecting a water-cooled welding torch, the power source's main power supply switch must be in the OFF position and the cooling unit switch must be in position 0.

A water connection kit can be ordered as an accessory, see chapter "Accessories".

Strain relief

Hook the strain relief onto the hook on the rear side of the feeder unit and the connection cable.

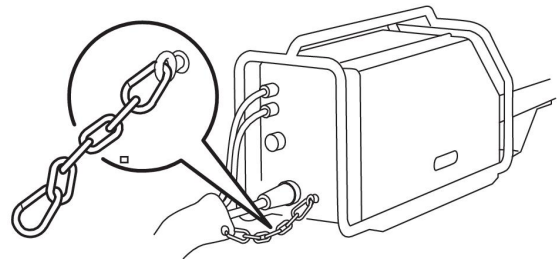

Safety contact switch

- 0 Welding OFF
- 1 Welding ON
- ☸ Heat ON (accessory) and welding OFF
The bobbin area is heated so that the welding wire is kept dry when welding.

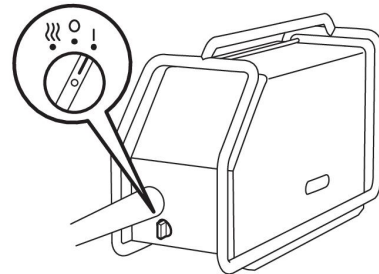

Gas flow control and solid/cored wire

Open the lid for access to the gas flow control and selection of the solid/cored wire.

- A** = Gas flow meter
- B** = Setting solid or cored wire
- C** = Display setting, in/min or m/min

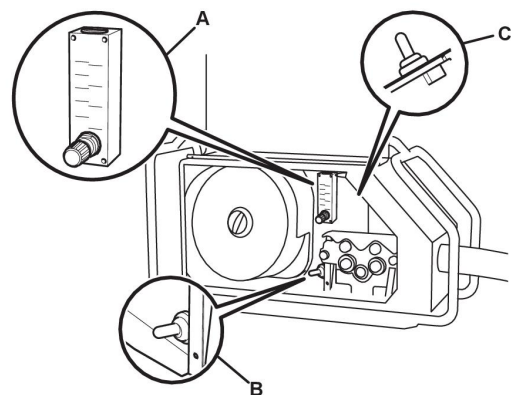

Wire selection – Solid wire

Short Circuit Termination (SCT) behavior is selected when the trigger is released, to adjust to welding with solid wire.

SCT is a way to stop the welding with some small short circuits to reduce the end crater and oxidation. It also gives the advantage of a good start performance with solid wire.



Wire selection – Cored wire

A constant burnback time is selected when the trigger is released, to adjust to welding with cored wire.



Gas purging

Gas purging is used when measuring the gas flow, or to flush any air or moisture from the gas hoses before welding starts. Gas purging takes place for as long as the button is held depressed and takes place without voltage or wire feed starting.



Wire inching

Wire inching is used when feeding wire without applying a welding voltage. The wire is fed as long as the button is depressed.



2-stroke

With 2-stroke, gas pre-flow starts when the welding torch trigger switch is pressed. The welding process then starts. Releasing the trigger switch stops welding entirely and starts gas post-flow.



4-stroke

With 4 stroke, the gas pre-flow starts when the welding torch trigger switch is pressed in and the wire feed starts when it is released. The welding process continues until the switch is pressed in again, when the switch is released the wire feed then stops the gas post-flow starts.



Voltage

Higher voltage increases the arc length and produces a hotter, wider arc.

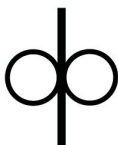

Wire feed speed

This sets the required feed speed of the filler wire in inches per minute (in/min) or meters per minute (m/min).

5.3 Wire feed pressure

Start by making sure that the wire moves smoothly through the wire guide. Then set the pressure of the wire feeder's pressure rollers. It is important that the pressure is not too high.

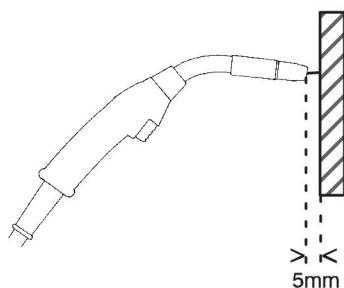

Figure A

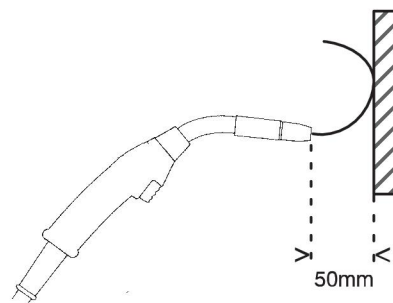

Figure B

To check that the feed pressure is set correctly, you can feed out the wire against an insulated object, e.g. a piece of wood.

When you hold the welding torch approx. 5 mm from the piece of wood (figure A) the feed rollers should slip.

If you hold the welding torch approx. 50 mm from the piece of wood, the wire should be fed out and bend (figure B).

5.4 Replacing and inserting wire

1. Open the side panel.
2. Disconnect the pressure sensor by folding it backward; the pressure rollers slide up.
3. Straighten out the new wire 4-8 in (10-20 cm). File away burrs and sharp edges from the end of the wire before inserting it into the wire feed unit.
4. Make sure that the wire goes properly into the feed roller's track and into the outflow nozzle or wire guide.
5. Secure the pressure sensor.
6. Close the side panel.

5.5 Changing feed rollers

1. Open the side panel.
2. Disconnect the pressure sensor (1) by folding it backward, the pressure rollers slide up.
3. Disconnect the pressure rollers (2) by turning the axle (3) 1/4 turn clockwise and pulling out the axle. The pressure rollers disconnect.
4. Disconnect the feed rollers (4) by unscrewing the nuts (5) and pulling out the rollers.

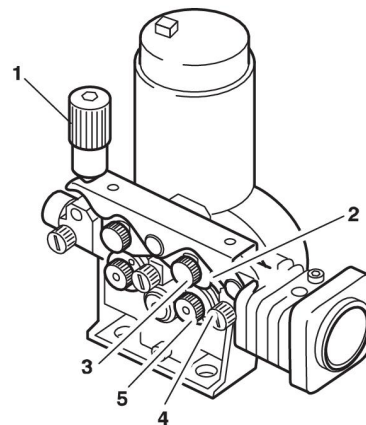

During installation, repeat the above in reverse order.

Choice of track in the feed rollers

Turn the feed roller with the dimensioning mark for the required track toward you.

6 MAINTENANCE



NOTE!

Regular maintenance is important for safe and reliable operation.



CAUTION!

All warranty undertakings from the supplier cease to apply if the customer attempts any work to rectify any faults in the product during the warranty period.

6.1 Inspection and cleaning

Wire feed unit

Regularly check that the wire feed unit is not clogged with dirt.

Cleaning and replacement of worn parts in the mechanism of the wire feed should take place at regular intervals in order to achieve trouble-free wire feeding. Note that if pretensioning is set too hard, this can result in abnormal wear on the pressure roller, feed roller, and wire guide.

The brake hub

The hub is adjusted when delivered.

Adjust the brake hub so that the wire is slightly slack when wire feed stops.

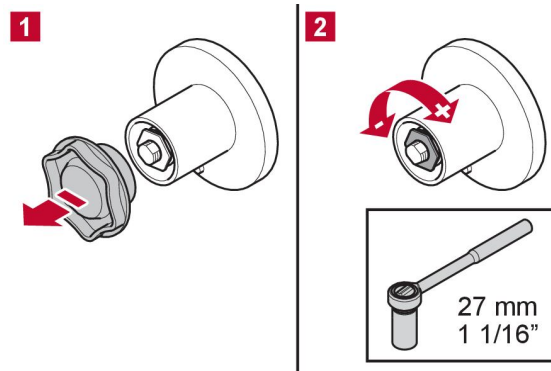

Welding torch

The wear parts of the welding torch should be cleaned and replaced at regular intervals in order to achieve trouble-free wire feeding. Regularly blow the wire guide clean and clean the contact tip.

7 ORDERING SPARE PARTS



CAUTION!

Repair and electrical work should be performed by an authorised ESAB service technician. Use only ESAB original spare and wear parts.

The Warrior™ YardFeed 200 and Warrior™ YardFeed 200w are designed and tested in accordance with international and European standards IEC/EN 60974-5 and IEC/EN 60974-10, Canadian standard CAN/CSA-E60974-5 and US standard ANSI/IEC 60974-5. Upon completion of service or repair work, it is the responsibility of the person(s) performing the work to ensure that the product still complies with the requirements of the above standards.

Spare parts and wear parts can be ordered through your nearest ESAB dealer, see the back cover of this document. When ordering, please state product type, serial number, designation and spare part number in accordance with the spare parts list. This facilitates dispatch and ensures correct delivery.

DIAGRAM

Warrior™ Yard Feed 200

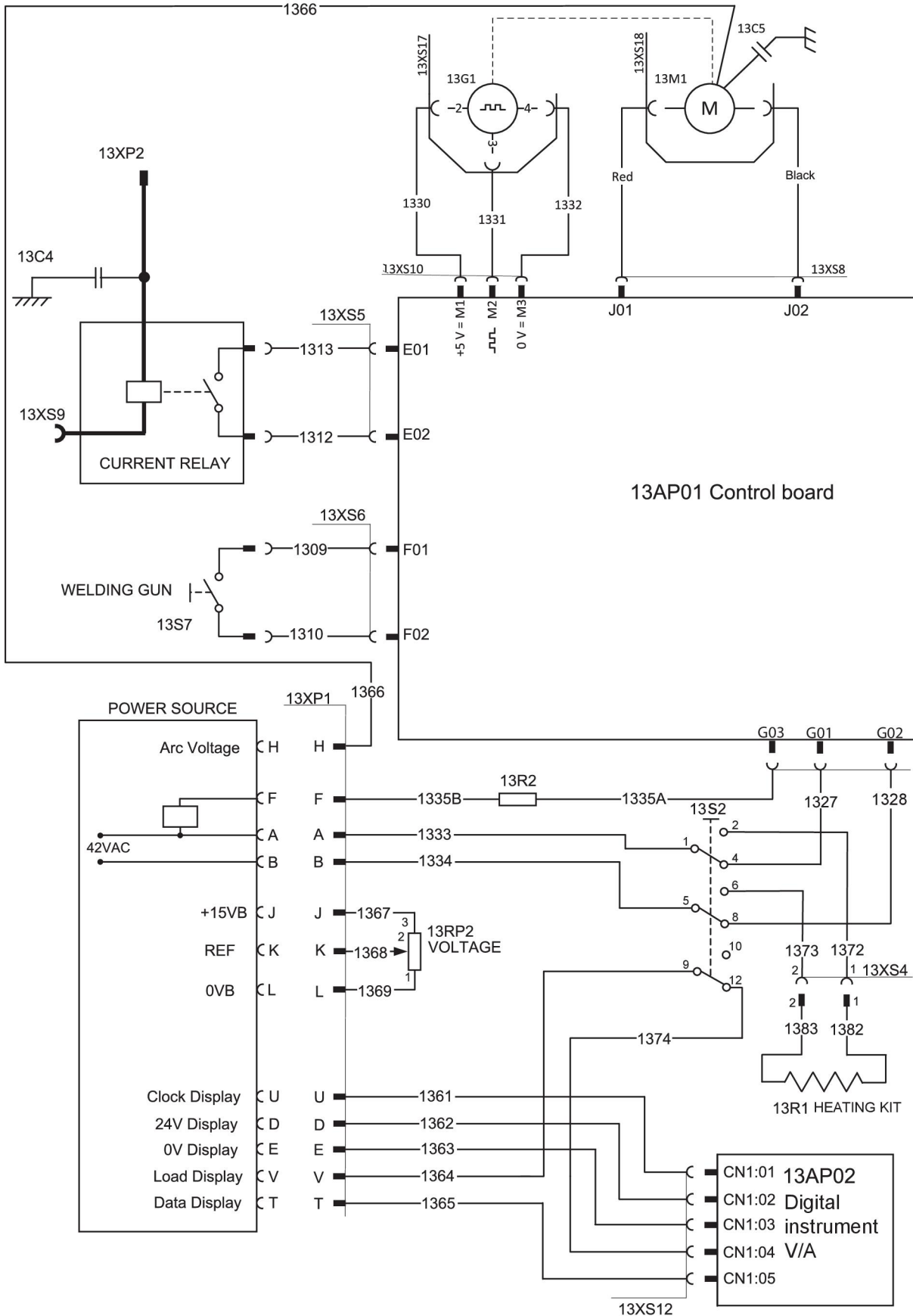

ORDERING NUMBERS

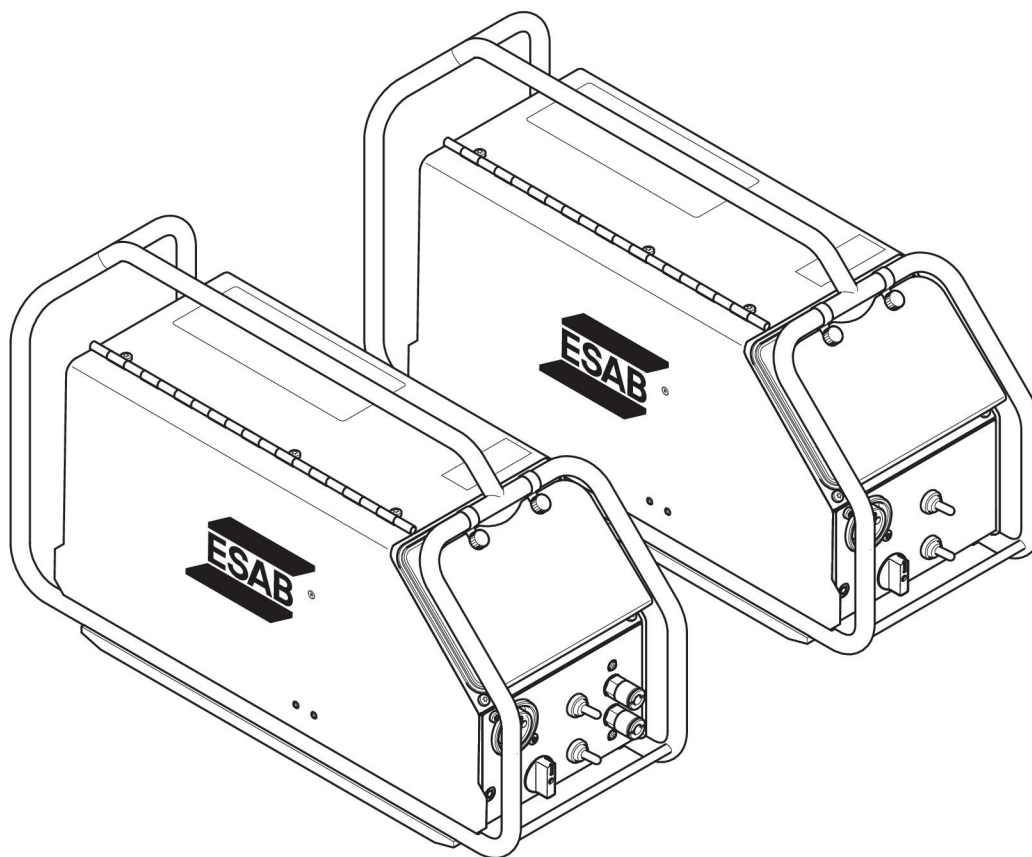

Ordering no.	Denomination	Type
0459 906 900	Warrior™ YardFeed 200	
0459 906 901	Warrior™ YardFeed 200w	with water cooling
0463 390 001	Spare parts list	

Instruction manuals and the spare parts list are available on the Internet at: www.esab.com

WEAR PARTS

Item	Ordering number	Denomination	Wire type	Wire dimensions
HI 1	0455 072 002	Intermediate nozzle	Fe, Ss & cored	0.079 in steel for .023-1/16 in (Ø 2.0 mm steel for 0.6-1.6 mm)
	0456 615 001	Intermediate nozzle	Al	Ø 2.0 mm plastic for 0.8-1.6 mm (0.079 in. plastic for .030-1/16 in.)
HI 2	0469 837 880	Outlet nozzle	Fe, Ss & cored	0.079 in steel for .023-1/16 in (0.079 in. steel for .023-1/16 in.)
	0469 837 881	Outlet nozzle	Al	Ø 2.0 mm plastic for 0.8-1.6 mm (0079 in. plastic for .030-1/16 in.)
HI 3	0191 496 114	Key		
HI 4	0215 701 007	Locking washer		
HI 5a	0459 440 001	Motor gear euro, drive gear		

WEAR PARTS

Item	Ordering number	Denomination	Wire type	Wire dimensions mm (in.)	Groove type	Roller markings
HI 5b	0459 052 001	Feed/pressure rollers	Fe, Ss & cored	Ø 0.6 & 0.8 (.023 & .030)	V	0.6 S2 & 0.8 S2
	0459 052 002	Feed/pressure rollers	Fe, Ss & cored	Ø 0.8 & 1.0 (.030 & .040)	V	0.8 S2 & 1.0 S2
	0459 052 003	Feed/pressure rollers	Fe, Ss & cored	Ø 0.9/1.0 & 1.2 (.035-.040 & 0.045)	V	1.0 S2 & 1.2 S2
	0459 052 013	Feed/pressure rollers	Fe, Ss & cored	Ø 1.4 & 1.6 (.055 & 1/16)	V	1.4 S2 & 1.6 S2
	0458 825 001	Feed/pressure rollers	Cored	Ø 0.9/1.0 & 1.2 (.035-.040 & 0.045)	V-knurled	1.0 R2 & 1.2 R2
	0458 825 010	Feed/pressure rollers	Cored	Ø 1.2 & 1.2 (0.045 & 0.045)	V-knurled	1.2 R2 & 1.2 R2
	0458 825 002	Feed/pressure rollers	Cored	Ø 1.2 & 1.4 (0.045 & .055)	V-knurled	1.2 R2 & 1.4 R2
	0458 825 003	Feed/pressure rollers	Cored	Ø 1.6 (1/16)	V-knurled	1.6 R2 & 2.0 R2
	0458 824 001	Feed/pressure rollers	Al	Ø 0.8 & 0.9/1.0 (.030 & .035-.040)	U	0.8 A2 & 1.0 A2
	0458 824 002	Feed/pressure rollers	Al	Ø 1.0 & 1.2 (.040 & 0.045)	U	1.0 A2 & 1.2 A2
	0458 824 003	Feed/pressure rollers	Al	Ø 1.2 & 1.6 (0.045 & 1/16)	U	1.2 A2 & 1.6 A2
<p>Only use pressure and feed rollers marked A2 , R2 or S2 . The rollers are marked with wire dimension in mm, some are also marked with inches.</p>						

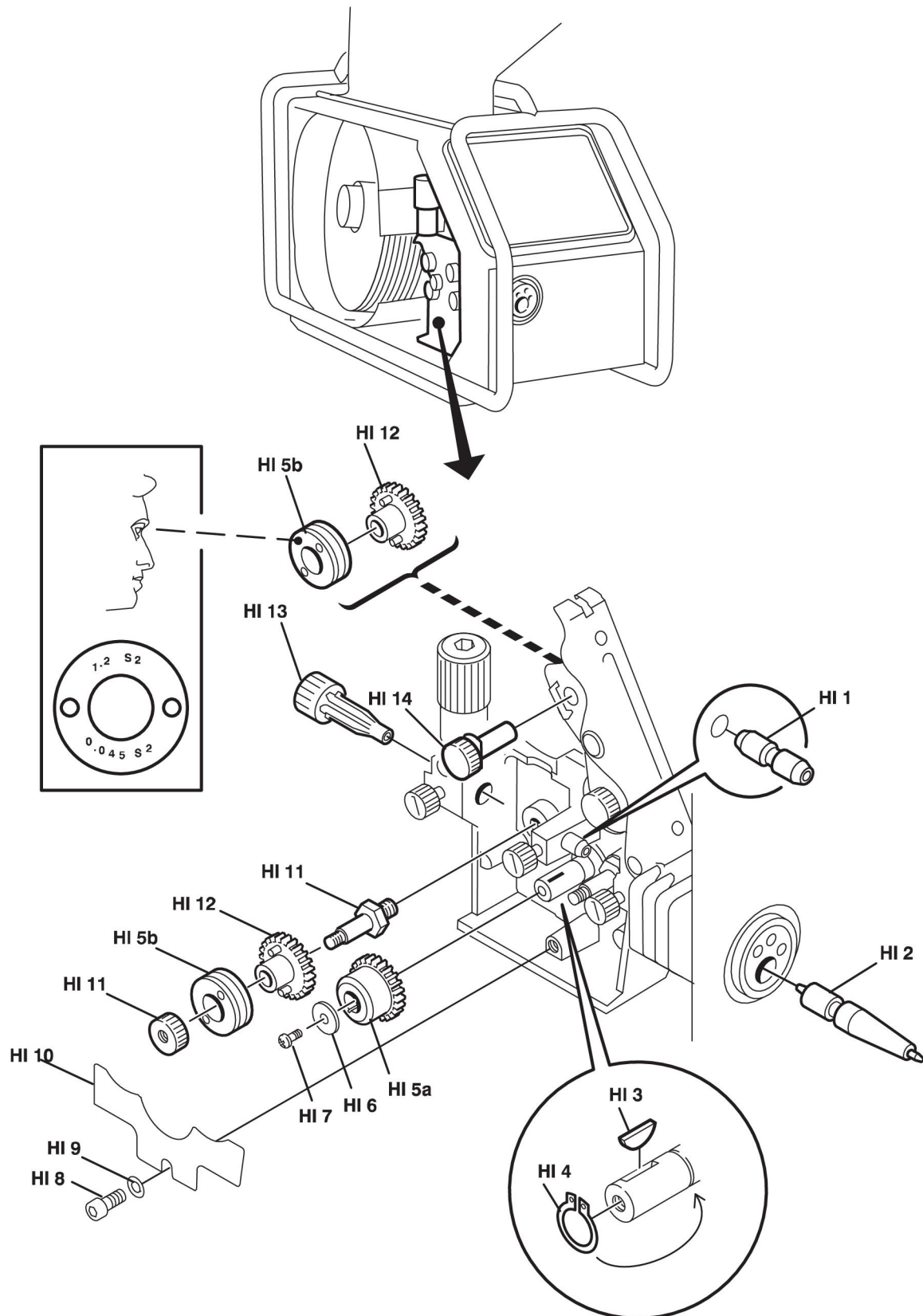

WEAR PARTS

Item	Ordering number	Denomination	Notes
HI 6		Washer	Ø 16/5×1
HI 7		Screw	M4×12
HI 8		Screw	M6×12
HI 9		Washer	Ø 16/8.4×1.5
HI 10	0469 838 001	Cover	
HI 11	0458 722 880	Axle and Nut	
HI 12	0459 441 880	Gear adapter	
HI 13	0455 049 001	Inlet nozzle	Ø 3 mm for 0.6-1.6 mm (.118 in for .023-1/16 in.) Fe, Ss, Al and cored wire)
	0460 007 001	Inlet nozzle	Long-life for Fe, Ss and cored wire
HI 14	0458 999 001	Shaft	

Welding with aluminum wire

In order to weld with aluminum wire, U-shaped rollers, nozzles and liners for aluminum wire **must** be used. It is recommended to use 3 m long welding torch for aluminum wire, equipped with appropriate wear parts.

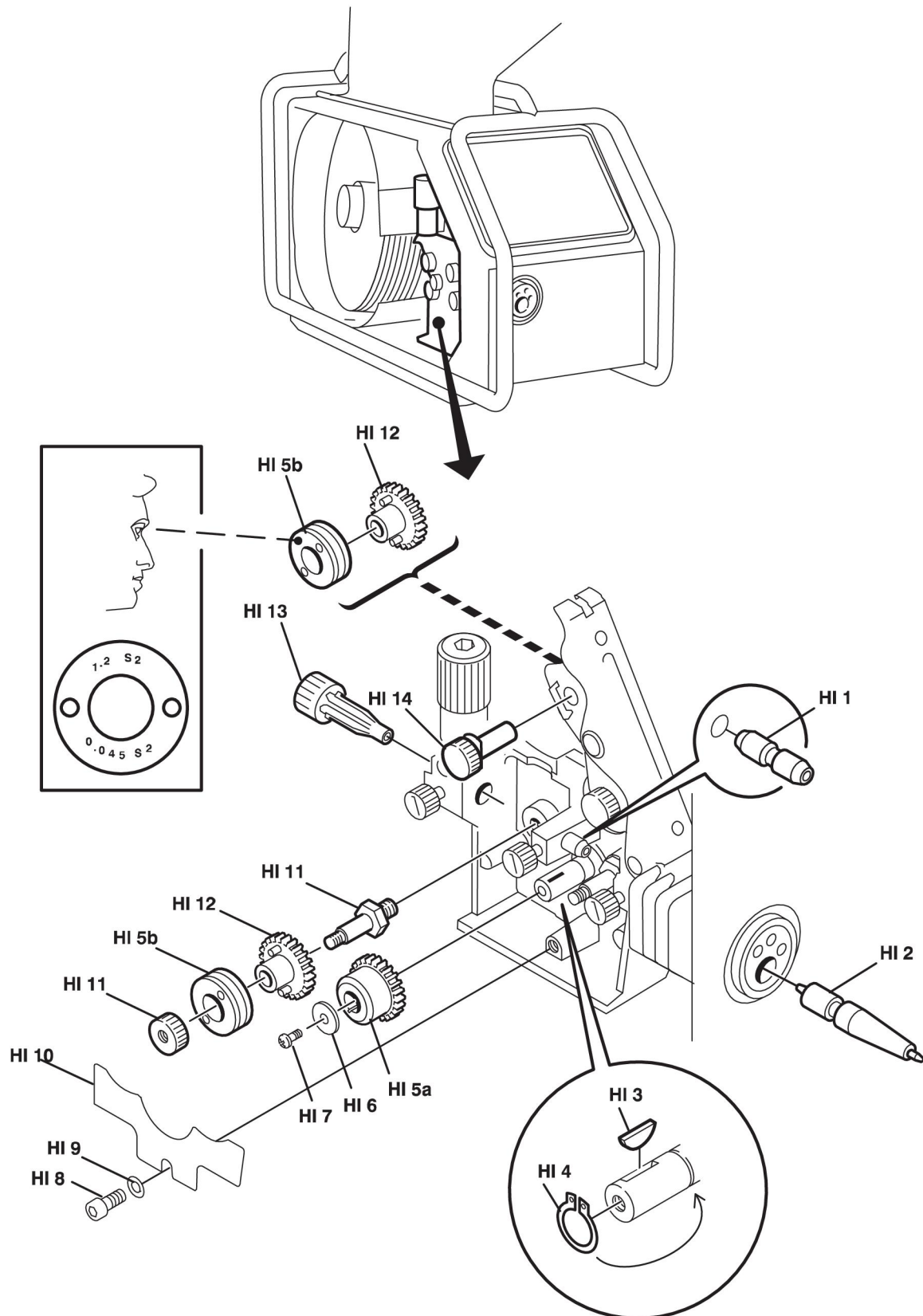

ACCESSORIES

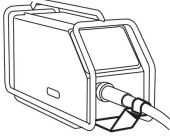
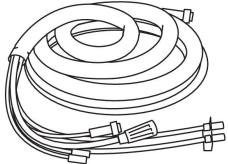
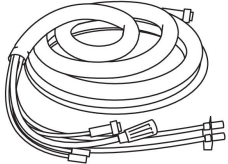
0457 341 881	Strain relief for welding gun	
Connection set air, 50 mm², 19/19 pole		
0459 836 562	10 m	
0459 836 563	15 m	
0459 836 564	25 m	
0459 836 565	35 m	
0459 836 566	50 m	
Connection set water, 50 mm², 19/19 pole		
0459 836 572	10 m	
0459 836 573	15 m	
0459 836 574	25 m	
0459 836 575	35 m	
0459 836 576	164 ft (50 m)	

ESAB subsidiaries and representative offices

Europe

AUSTRIA

ESAB Ges.m.b.H
Vienna-Liesing
Tel: +43 1 888 25 11
Fax: +43 1 888 25 11 85

BELGIUM

S.A. ESAB N.V.
Heist-op-den-Berg
Tel: +32 15 25 79 30
Fax: +32 15 25 79 44

BULGARIA

ESAB Kft Representative Office
Sofia
Tel: +359 2 974 42 88
Fax: +359 2 974 42 88

THE CZECH REPUBLIC

ESAB VAMBERK s.r.o.
Vamberk
Tel: +420 2 819 40 885
Fax: +420 2 819 40 120

DENMARK

Aktieselskabet ESAB
Herlev
Tel: +45 36 30 01 11
Fax: +45 36 30 40 03

FINLAND

ESAB Oy
Helsinki
Tel: +358 9 547 761
Fax: +358 9 547 77 71

GREAT BRITAIN

ESAB Group (UK) Ltd
Waltham Cross
Tel: +44 1992 76 85 15
Fax: +44 1992 71 58 03

ESAB Automation Ltd
Andover

Tel: +44 1264 33 22 33
Fax: +44 1264 33 20 74

FRANCE

ESAB France S.A.
Cergy Pontoise
Tel: +33 1 30 75 55 00
Fax: +33 1 30 75 55 24

GERMANY

ESAB Welding & Cutting GmbH
Langenfeld
Tel: +49 2173 3945-0
Fax: +49 2173 3945-218

HUNGARY

ESAB Kft
Budapest
Tel: +36 1 20 44 182
Fax: +36 1 20 44 186

ITALY

ESAB Saldatura S.p.A.
Bareggio (Mi)
Tel: +39 02 97 96 8.1
Fax: +39 02 97 96 87 01

THE NETHERLANDS

ESAB Nederland B.V.
Amersfoort
Tel: +31 33 422 35 55
Fax: +31 33 422 35 44

NORWAY

AS ESAB
Larvik
Tel: +47 33 12 10 00
Fax: +47 33 11 52 03

POLAND

ESAB Sp.zo.o.
Katowice
Tel: +48 32 351 11 00
Fax: +48 32 351 11 20

PORTUGAL

ESAB Lda
Lisbon
Tel: +351 8 310 960
Fax: +351 1 859 1277

ROMANIA

ESAB Romania Trading SRL
Bucharest
Tel: +40 316 900 600
Fax: +40 316 900 601

RUSSIA

LLC ESAB
Moscow
Tel: +7 (495) 663 20 08
Fax: +7 (495) 663 20 09

SLOVAKIA

ESAB Slovakia s.r.o.
Bratislava
Tel: +421 7 44 88 24 26
Fax: +421 7 44 88 87 41

SPAIN

ESAB Ibérica S.A.
San Fernando de Henares
(MADRID)
Tel: +34 91 878 3600
Fax: +34 91 802 3461

SWEDEN

ESAB Sverige AB
Gothenburg
Tel: +46 31 50 95 00
Fax: +46 31 50 92 22

ESAB International AB

Gothenburg
Tel: +46 31 50 90 00
Fax: +46 31 50 93 60

SWITZERLAND

ESAB Europe GmbH
Baar
Tel: +41 1 741 25 25
Fax: +41 1 740 30 55

UKRAINE

ESAB Ukraine LLC
Kiev
Tel: +38 (044) 501 23 24
Fax: +38 (044) 575 21 88

North and South America

ARGENTINA

CONARCO
Buenos Aires
Tel: +54 11 4 753 4039
Fax: +54 11 4 753 6313

BRAZIL

ESAB S.A.
Contagem-MG
Tel: +55 31 2191 4333
Fax: +55 31 2191 4440

CANADA

ESAB Group Canada Inc.
Mississauga, Ontario
Tel: +1 905 670 0220
Fax: +1 905 670 4879

MEXICO

ESAB Mexico S.A.
Monterrey
Tel: +52 8 350 5959
Fax: +52 8 350 7554

USA

ESAB Welding & Cutting
Products
Florence, SC
Tel: +1 843 669 4411
Fax: +1 843 664 5748

Asia/Pacific

AUSTRALIA

ESAB South Pacific
Archerfield BC QLD 4108
Tel: +61 1300 372 228
Fax: +61 7 3711 2328

CHINA

Shanghai ESAB A/P
Shanghai
Tel: +86 21 2326 3000
Fax: +86 21 6566 6622

INDIA

ESAB India Ltd
Calcutta
Tel: +91 33 478 45 17
Fax: +91 33 468 18 80

INDONESIA

P.T. ESABindo Pratama
Jakarta
Tel: +62 21 460 0188
Fax: +62 21 461 2929

JAPAN

ESAB Japan
Tokyo
Tel: +81 45 670 7073
Fax: +81 45 670 7001

MALAYSIA

ESAB (Malaysia) Snd Bhd
USJ
Tel: +603 8023 7835
Fax: +603 8023 0225

SINGAPORE

ESAB Asia/Pacific Pte Ltd
Singapore
Tel: +65 6861 43 22
Fax: +65 6861 31 95

SOUTH KOREA

ESAB SeAH Corporation
Kyungnam
Tel: +82 55 269 8170
Fax: +82 55 289 8864

UNITED ARAB EMIRATES

ESAB Middle East FZE
Dubai
Tel: +971 4 887 21 11
Fax: +971 4 887 22 63

Africa

EGYPT

ESAB Egypt
Dokki-Cairo
Tel: +20 2 390 96 69
Fax: +20 2 393 32 13

SOUTH AFRICA

ESAB Africa Welding & Cutting
Ltd
Durbanville 7570 - Cape Town
Tel: +27 (0)21 975 8924

Distributors

For addresses and phone numbers to our distributors in other countries, please visit our home page

www.esab.com



www.esab.com

